

Chapter 7 Digital Output (DO) Circuit

The digital outputs of FBs-PLC are available in the following two structures: the 5VDC ultra high speed Line-driver type differential output (i.e., one output occupying two terminals), and the single end output circuit for saving terminals. There are three kinds of output device for the single end output, which are relays, TRIAC and transistors. Since the relay and TRIAC are bilateral, even when used in single end output, they can serve as SINK or SRCE output. The transistor, however, because of its polarities, after being used as single end common output, its SINK and SRCE polarities are exactly the opposite (common point Cn of SINK output must connect to negative end of DC power). Therefore, the product model of transistor output of FBs-PLC for SINK and SRCE is distinct. At the right side of terminal block of FBs-PLC, there is a place for making SINK or SRCE label. The following are labeling examples of: ① SINK output models in FBs-PLC ② Transistor SRCE output model ③ Relay of TRIAC models with no SIN /SRCES polarity :

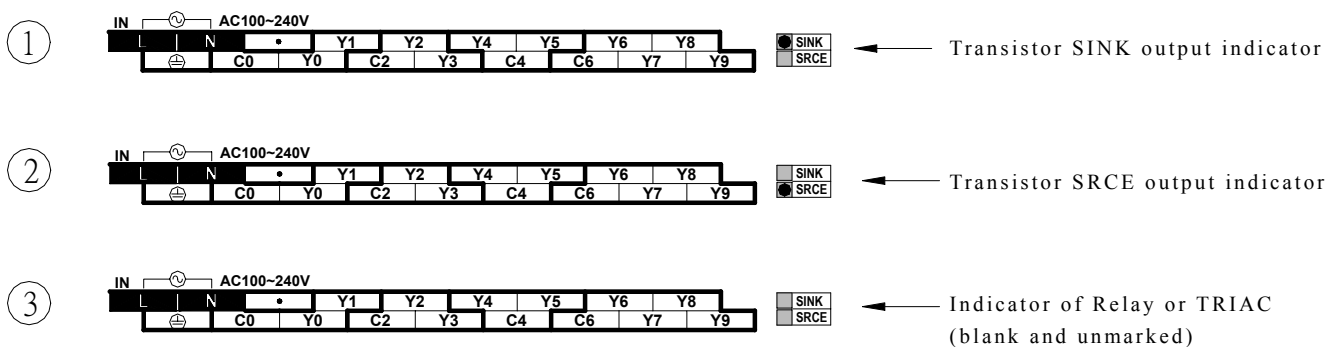

7.1 Specifications of Digital Output Circuit

Specification	Item	Differential Output	Single End Transistor Output			Single End Relay Output	Single End TRIAC Output
		Ultra High Speed	High Speed	Medium Speed	Low Speed		
Maximum swithing (working)Frequency		750KHz	100KHz	20KHz	200HZ	For ON/OFF, not for frequent exchange	
Working Voltage		5VDC	5~30VDC			<250VAC,30VDC	100~240VAC
Maximum Load Current	Resistive	50mA	0.5A	0.1A	0.5A	2A/single, 4A/common	1A
	Inductive					80VA	15VA/100VAC 30VA/200VAC
Maximum Voltage Drop (@ maximum load)		—	0.6V	2.2V	1.2V	0.06V(initial)	1.2Vrms
Minimum Load		—	—			2mA/DC power	25mA
Leakage Current		—	< 0.1 mA/30VDC			—	2mA
Maximum Output Delay Time	ON→OFF	200nS	200nS	15 μ S	1mS	10mS	1mS
	OFF→ON			30 μ S			1/2AC period
Output Status Indication		LED is bit when "ON" , dark when "OFF"					
Over Current Protection		N/A					
Isolation Type		PhotoCoupler Isolation			Electromagnetic Isolation	Photo Coupler Isolation	
SINK/SRCE Output Type	Independent Dual Terminals for arbitrary connection	Choose SINK/SRCE by models and non-exchangeable			Bilateral device, can be arbitrarily set to SINK/SRCE output		

Warning

1. No over current protection is available in the FBs series PLC. Except for the 5V differential output circuit, all other output circuits have to be added with over current or short circuit protections externally, such as fuses, in applications with safety concern.
2. Terminals labeled by "●" on the terminal block are empty contacts, which cannot be connected with any wire to maintain the required safety clearance and to avoid damage to the unit.
3. In situations where simultaneous operations of outputs (such as reverse/forward action of motor) pose safety concerns, besides the interlock in PLC programs, additional interlock circuits are needed outside PLC, as shown below :

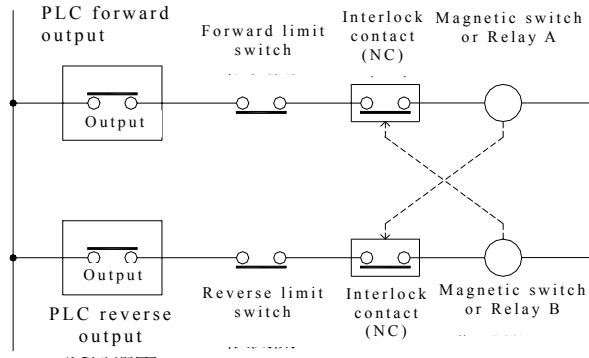

7.2 5VDC Ultra High Speed Line-Driver Differential Output Circuit and its Wiring

The 5VDC ultra high speed Line-Driver differential output circuit of FBs-PLC is only available for the main unit of the MN model. Its output can connect to general photocoupler circuit or Line-Receiver input circuit, with the connection shown in the figure below. To improve noise immunity and maintain signal quality, please use twisted pair with shield (or aluminum foils) for connection and connect the shield with SG of PLC and FG of the driver. Please also operate in A/B phase driving mode (because A/B phase driving can automatically cancel interferences from noise pulses).

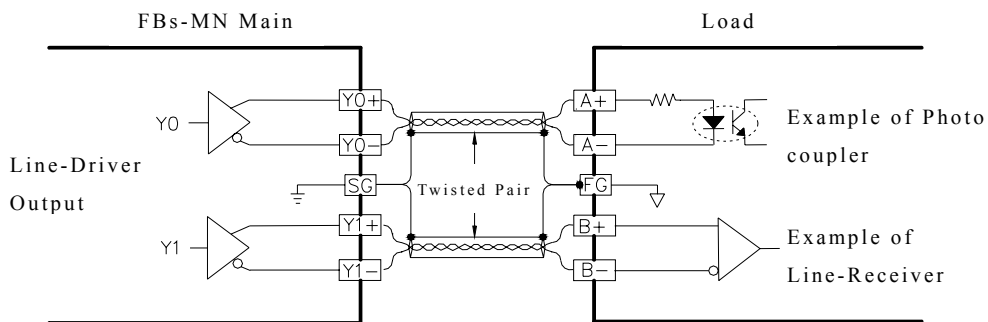

(With frequency up to 750KHz, for use in high speed and large noise environments)

7.3 Single End Output Circuit

Except that the 5VDC ultra high speed output circuit has independent dual terminal outputs,
H7-2

all other output circuits such as relays, transistors or TRIAC are single end output structure. A single end output in each digital output (DO) takes up only one terminal. But since any output device has two ends, the one end of several output devices have to be connected together to one common point (called output common) for single end output. Then each output point can output via this common point. The more output device share a same common points, the more terminals are saved, while relatively increasing the current running through the common point. Combination of any output common with its individual single end outputs are called a Common Output Block, which is available in 2, 4 and 8PTs (high-density module) in FBs-PLC. Each Common Output Block is separated from one another. The common terminal has a label initiated with letter “C”, while its numbering is determined by the minimum Yn number which comprise the output block. In the example of the figure below, the number of common terminal of output block Y2 and Y3 is C2, while the number of common terminal of output Block Y4, Y5, Y6 and Y7 is C4. The various single end common output circuits are described below :

7.3.1 Structure and Wiring of Single End Relay Output Circuit

Because relay contacts have no polarity, it can be applied for AC or DC load power. Each relay can provide current up to 2A. The maximum rated current in all output commons of FBs-PLC is 4A. Its mechanical lifetime can reach up to 2 million times, while the contacts have a shorter lifetime. The lifetime also varies depending on working voltage, load type (power factor $\cos \phi$) and contact current. The relation between them is plotted in the figure below. In the case of pure resistive load ($\cos \phi = 1.0$) at 120VAC and 2A, the lifetime of contacts is about 250 thousand times. While for high inductive or capacitive load with $\cos \phi$ up to 0.2 and current within 1A, the lifetime decreases rapidly to about 50 thousand times (AC200V) or 80 thousand times (AC120V).

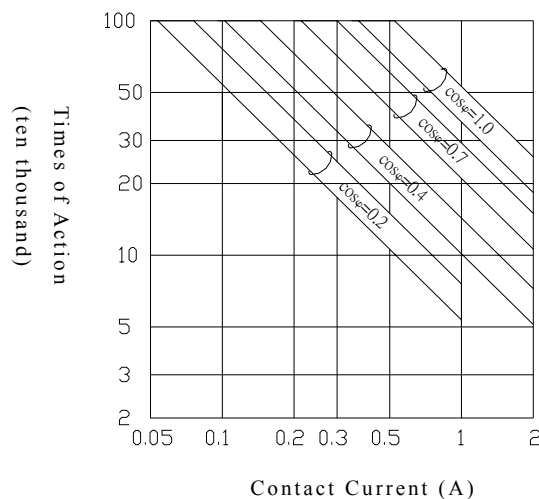
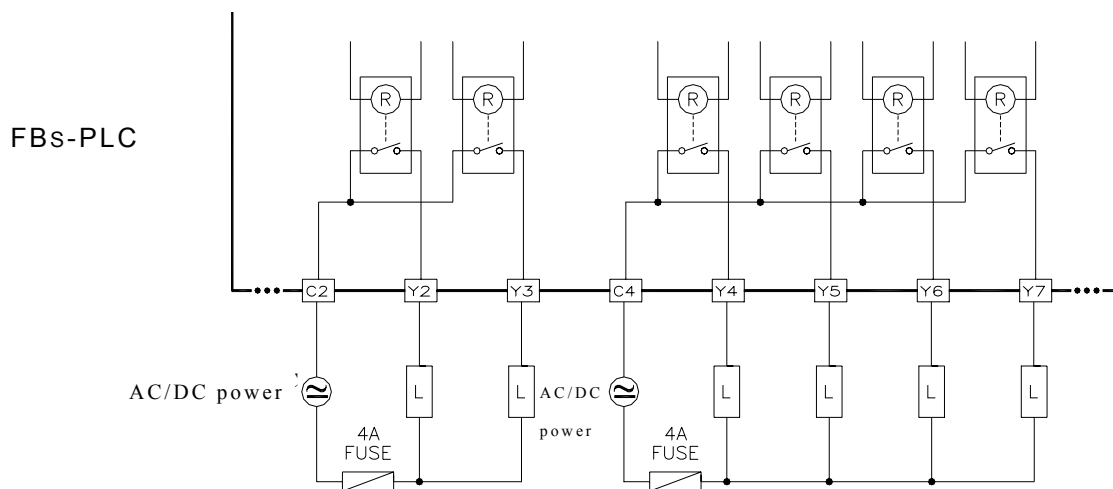

7.3.2 Structure and Wiring of Single End Transistor SINK and SRCE Output

Circuit

A. Transistor Single End SINK Output

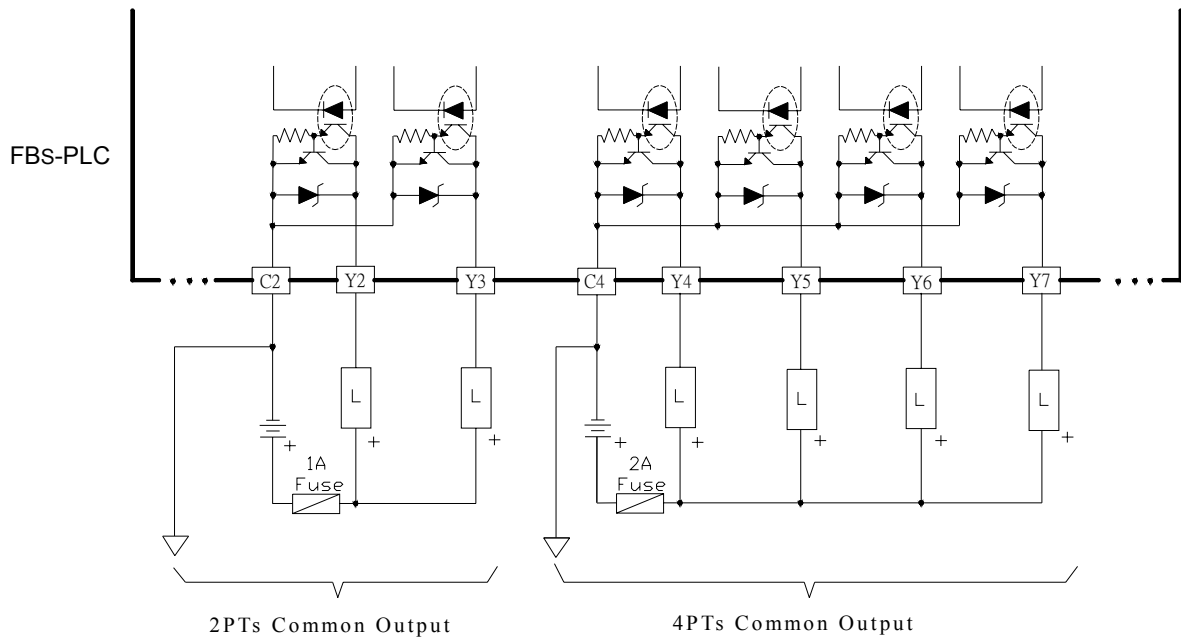

B. Transistor Single End SRCE Output

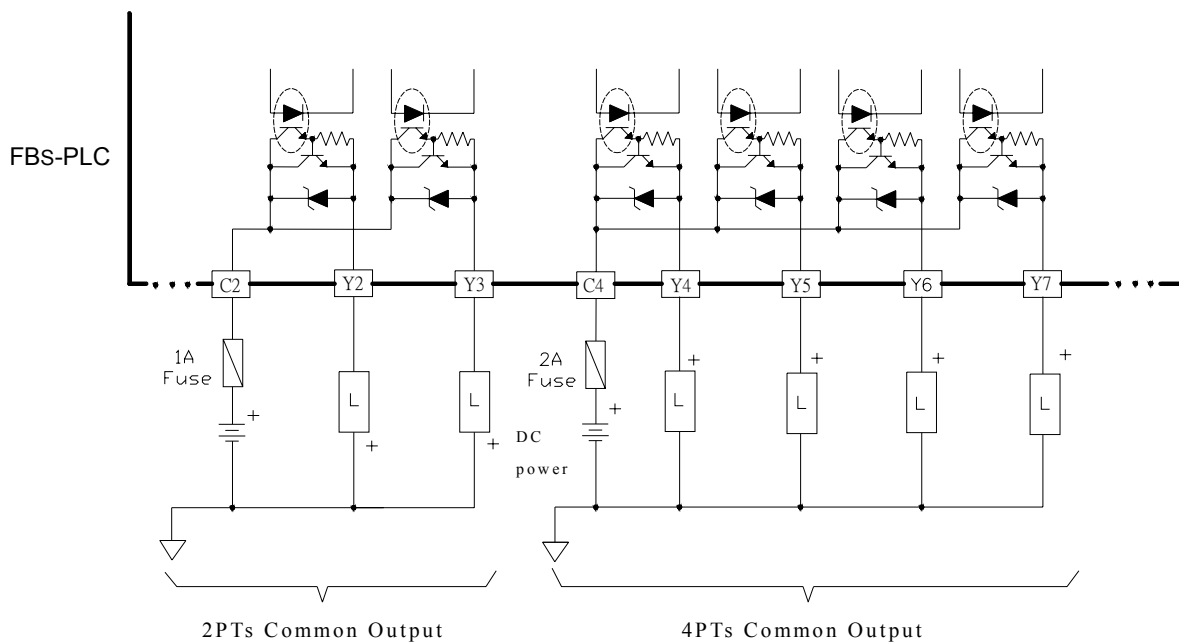

The figure above uses output blocks of 2PTs common and 4PTs common as an example to explain the differences in structural and wiring for SINK and SRCE output circuits, respectively. (8PTs common has the same block structure and wiring, except with different point number) The single end SINK output and SRCE transistor output in FBS-PLC are different models. The user must check whether it is SINK output model or SRCE output model when purchasing.

7.3.3 Structure and Wiring of Single End TRIAC Output Circuit

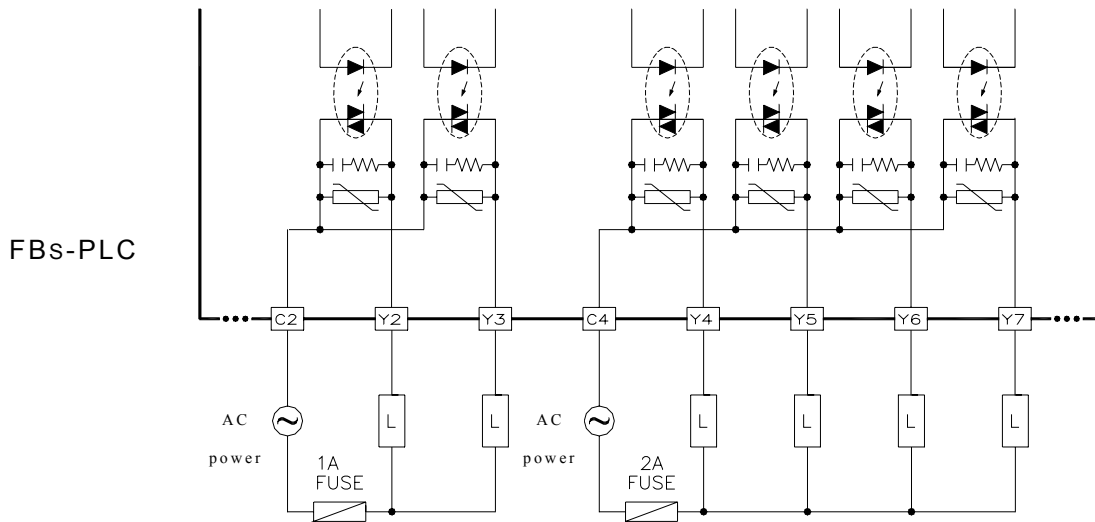

- TRIAC output can only be used for AC load. Furthermore, a load current larger than the holding current (25mA) is required to keep TRIAC conducting. Therefore, when the load current is less than 25mA, a Dummy load must be connected parallel with load to make the load current larger than the TRIAC holding current. Besides, note that even when TRIAC output is open (OFF), there still exists a leakage current of 1mA (AC100V) or 2mA (AC200V), which may trigger actions in loads that can be activated by small currents. Connection of Dummy load in parallel with the load described above can solve this problem.

7.4 Speed up the Single End Transistor Output Circuit (only applicable to high- and medium-speed)

Either with the SINK or SRCE structure in single end output transistor circuit, when the transistor switches from ON to OFF, the junction capacitor between transistor CE electrodes should be charged to near the load voltage VDD before it can stop the current running through the photocoupler inside the load, which increase the OFF time and decrease the response speed. This problem can be solved by adding a Dummy load to accelerate charging rate and speed up the working frequency of transistor output. For the transistor output in FBS-PLC, Dummy load that are added to the high- and medium-speed transistor output and generate a load current of 20~50mA is adequate. For low speed transistor where its driving capability (0.5A) but speed is concerned, adding a Dummy load only decreases its driving capability without any significant improvement and hence is not recommended. The following diagram shows how to add a Dummy load to SINK and SRCE transistor output.

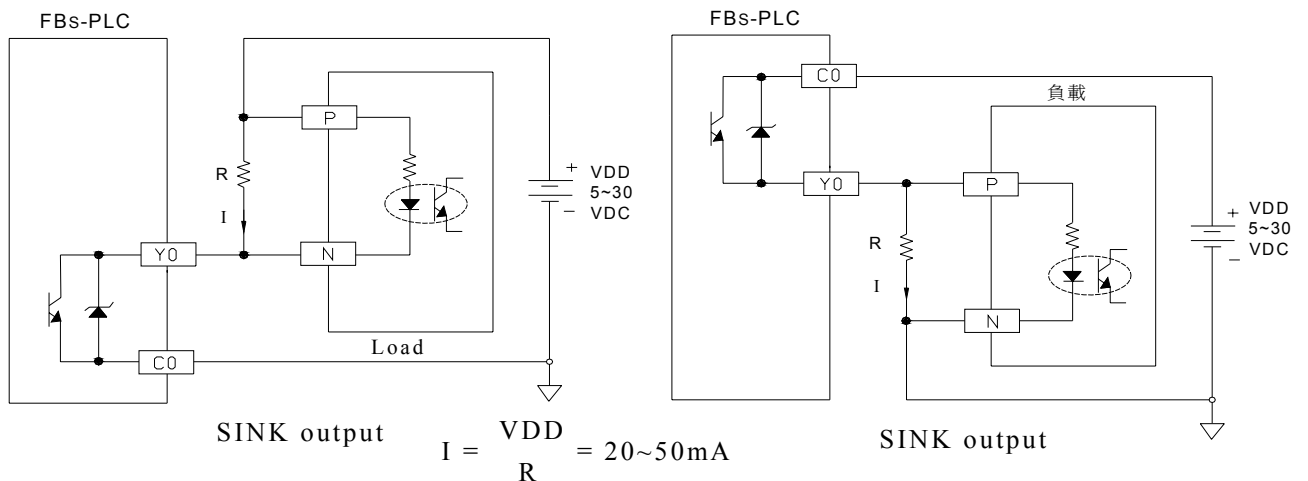

7.5 Output Device Protection and Noise Suppression in DO Circuit

Since the digital output circuits are mainly used for the ON/OFF switching operation, the output components such as relays, transistors and TRIAC can be deemed as kinds of switch components. Normally, surge currents or counter-electromotive force voltages are generated during the ON/OFF operation of these switch components. The effect of surge currents or counter-electromotive force voltages is particularly serious when heavy capacitive or inductive loads are incorporated, which may cause damage to the output components or generate noises in other electronic circuits and equipment. Among those three FBs-PLC output components, where TRIAC require no special treatment because of their features of smaller rated current, zero cross in ON/OFF, and built-in protection circuits, special consideration should be given to relays and transistors when they are used in high power applications or connected with capacitive or inductive loads and are described in the following:

7.5.1 Protection of Relay Contacts and Noise Suppression

Because the relay contacts are used to contact switch components having extremely low resistance, the surge current I_r generated instantly upon turning on the relay is normally pretty strong (even if the steady load current is very small). Under such strong surge, the contact tends to melt and stick due to extreme temperature in such a way that the relay cannot trip when it is disconnected. In addition, when the relay connections are OFF, large di/dt is generated because of the instantaneous change from low resistance to open circuit (∞) soon after following the tripping of contact. As a result, an extremely strong counter-electromotive force voltage is induced, which creates sparks between the electrodes of two relay contacts and results in poor contact due to carbon deposits. Among those three output components, either in ON or OFF state, very serious interference can be caused by the surge current or the counter-electromotive of the relay. The solutions to this problem are listed as follows:

A. Suppression of Surge Current \Rightarrow Connect a small resistor R in series to lower the surge current, but note that too large R will affect the driving capability or cause too much voltage drop.

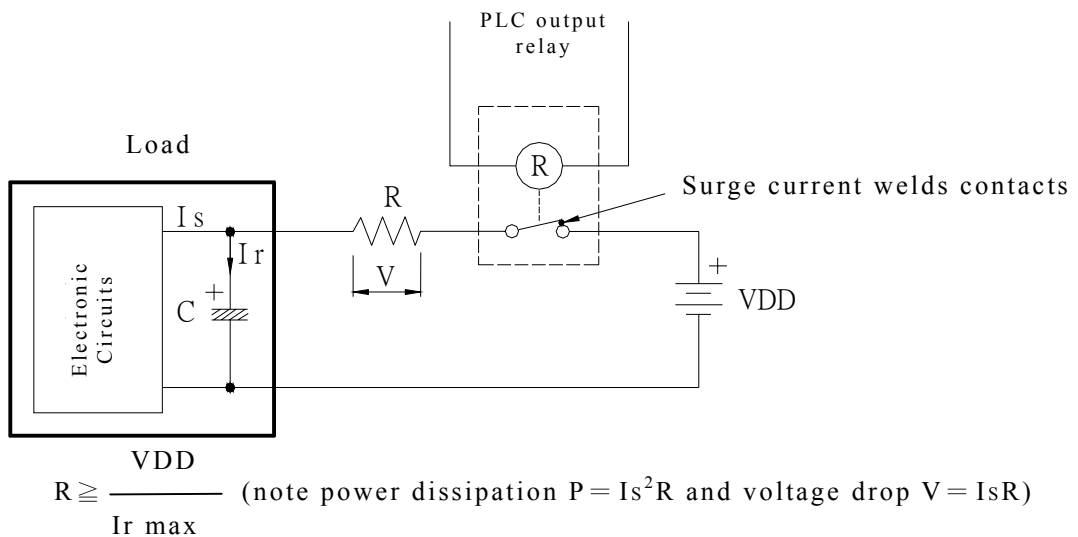

$I_r \text{ max of relay in FBS-PLC} = 5A$

B. Suppression of Counter-Electromotive Force

For the inductive load, whether in AC or DC power, suppression devices must be connected in parallel to both its ends to protect the relay contacts and lower noise interference. The schematic diagrams for AC and DC powers are shown below, respectively:

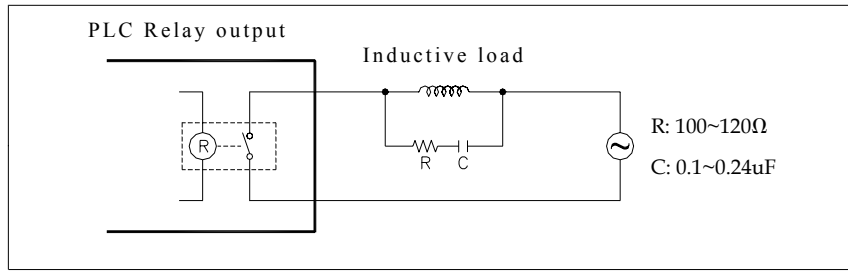

Scheme of AC power load

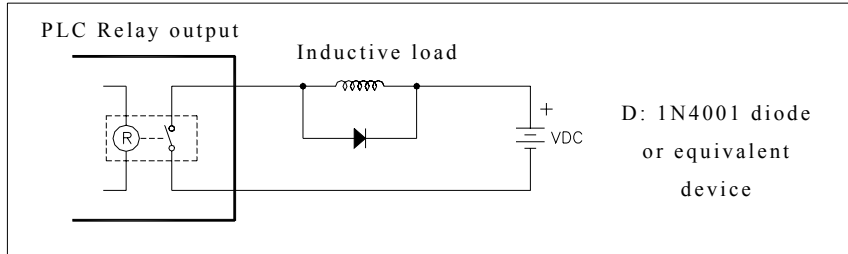

Suppress by a diode in DC power load (for low power)

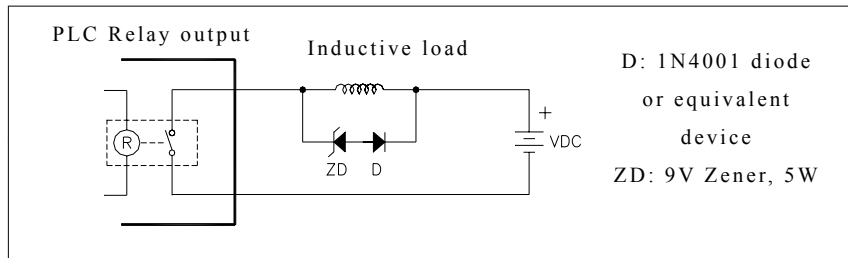

Suppress by a diode + Zener in DC power load (for high power and frequent ON/OFF)

7.5.2 Protection of Transistor Output and Noise Suppression

The transistor output in FBs-PLC already includes Zener diode for counter-electromotive force, which is sufficient for low power inductive load and medium frequency of ON/OFF application. In conditions of high power or frequent ON/OFF, please construct another suppression circuit to lower noise interference and prevent voltage from exceeding the limit or overheating that may damage the transistor output circuit.

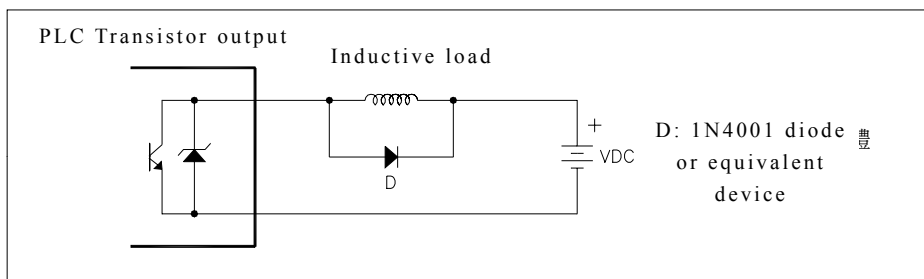

Suppress by a diode (for low power)

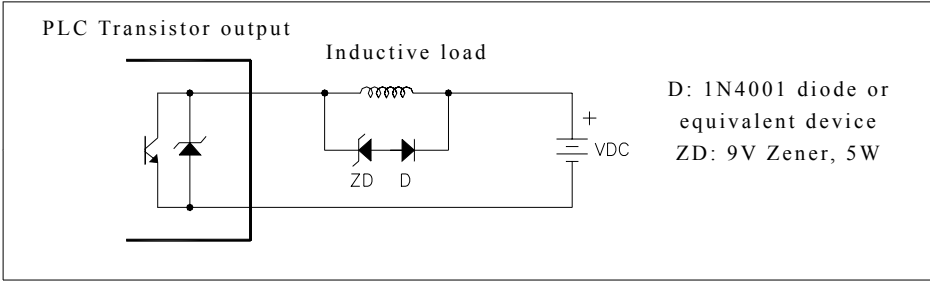

Suppress by a diode + Zener (high power and frequent ON/OFF)